

# Operation of the Helios 1 Compact Synchrotron RF System

R J Anderson, E P Gibbons, S T Perry<sup>1</sup>  
Synchrotron Division, Oxford Instruments Ltd,  
Osney Mead, Oxford,  
OX2 0DX, England

## Abstract

The Helios 500 MHz rf system is based closely on the waveguide fed window coupled cavity technique used by the SRS at Daresbury Laboratory [1], it uses the same spherical cavity profile, window coupling and non-contacting tuner design.

In contrast to the SRS, stringent reflected power limits are imposed by the rf source klystron as it is not protected by a circulator. To minimise the reflected power in this situation a method of dynamically adjusting the cavity to waveguide match has to be used. In addition a non-linear control technique had to be developed to further control the power reflected to the klystron.

The dynamic matching technique, which is based on measurements of stored beam current, beam energy and cavity voltage, is analysed. The system, which has now been operating successfully since mid 1990, has enabled the design approach to be closely investigated. Some of the operational experience obtained is presented.

## 1. INTRODUCTION

Helios 1 consists of a 200 MeV linear accelerator and race-track shaped electron storage ring designed to store up to 200 mA at 700 MeV. A pair of superconducting dipoles are placed at either end of the race-track, each deflecting the stored beam through 180°. Reference [2] describes Helios 1 in detail and covers the overall commissioning results.

Helios was designed and built by Oxford Instruments as a commercial X-ray lithography tool.

## 2. THE HELIOS 1 RF SYSTEM

The Helios 1 rf source is a standard broadcasting klystron (an EEV K3672BCD). This is rated for a maximum permissible reflected power of 2kW at 50 kW output.

Power is fed to the cavity via a coaxial line approximately 20m long. This is then connected via WR1800 waveguide through a dual directional coupler, then E-plane and H-plane higher order mode (HOM) filters. The power then reaches the waveguide to cavity transition illustrated in figure 1.

The transition is a waveguide section with a circular hole in one of its short walls which accepts the cavity's ceramic vacuum window. The final component in the waveguide feed system is the transparent matcher which modifies the natural

coupling factor provided by the cavity window. This acts like a sliding short circuit and must be adjusted to minimise the power reflected from the cavity back to the rf source. The matcher and HOM filters are based on SRS designs which are described further in [1] however unlike Helios 1, the matchers of the 4 SRS cavities are left in a fixed position.

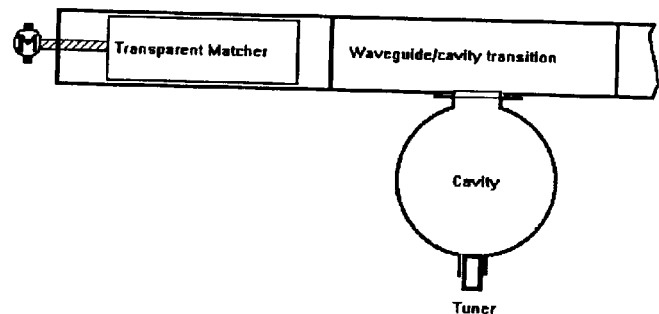

Figure 1. Waveguide feed and cavity

## 3. THE DYNAMIC MATCHER ALGORITHM

Analysis of the matcher is based on the model illustrated in figure 2 below.

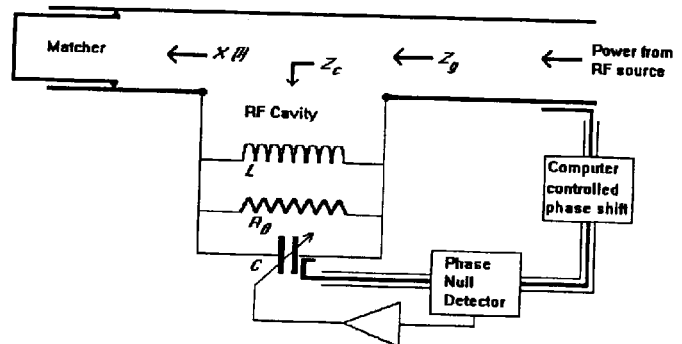

Figure 2. Cavity and feed circuit model

The cavity is represented by a shunt combination of inductance ( $L$ ), capacitance ( $C$ ) and resistance ( $R_0$ ).

The cavity is placed in series with a transmission line representing the waveguide feed from the rf source (additional waveguide components such as the higher order mode filters are ignored on the basis that they represent an arbitrary additional length of transmission line at the driven frequency). The transparent matcher is represented by a sliding short circuit on the transmission line beyond the cavity transition.

Figure 2 includes a phase null detector to control cavity tuning, this is the conventional method of compensating for the beam induced back voltage in the cavity as beam is

<sup>1</sup>The contributions to the development of the cavity detune algorithm made by the Helios shift teams and in particular the recent work done by Al Weger, Jan Uythoven and Nigel Crosland is gratefully acknowledged.

accumulated at injection energy. Also illustrated is a computer controlled phase shifter, the function of which is explained at the end of section 3.

On the principle that close to its resonant frequency, a cavity can be represented by a simple LCR shunt combination, the complex impedance  $Z_c$  of this shunt combination may be expressed as

$$Z_c = R_0 \cdot \cos \psi \cdot e^{j\psi} \quad (1)$$

where  $\psi$  is the phase difference between the vectoral sum of the currents flowing through the LCR combination and the voltage across it. The phase difference is a function of the quality factor  $Q$  of the cavity coupled to the waveguide, the resonant frequency of the cavity  $\omega_0$  and the degree of de-tune  $\Delta\omega$ . When  $\Delta\omega \ll \omega_0$  the following approximation is valid:

$$\tan \psi \cong \frac{2 \cdot Q \cdot \Delta\omega}{\omega_0} \quad (2)$$

$Q$  can be measured, and the value of  $R_0$  for the case of a non beam loaded cavity deduced from a perturbation measurement of  $R_0/Q$

The effect of beam loading is to reduce  $R_0$  to a beam loaded value  $R_b$ . This beam loaded value can be calculated from the commonly used relation

$$\frac{R_0}{R_b} = 1 + \left[ \frac{P_{\text{rad}}}{P_{\text{cu}}} \right] \quad (3)$$

This is often termed the coupling ratio or  $\beta$  (see reference [3] for a derivation). Here  $P_{\text{rad}}$  (W) is the total power radiated as synchrotron radiation and is a function of stored beam current  $I_b$  (A), bend radius  $a$  (m) and beam energy  $E$  (MeV).  $P_{\text{cu}}$  (W) is the power dissipated in the cavity walls which depends on the peak cavity voltage  $V_c$  (V), thus:

$$\frac{P_{\text{rad}}}{P_{\text{cu}}} \cong \frac{8.85 \times 10^{-8} \cdot I_b \cdot E^4}{\frac{a}{2 \cdot R_0}} \quad (4)$$

here  $R_0$  is expressed in transit time corrected 'circuit' Ohms rather than 'linac' Ohms hence the factor of 2 in (4).

Let the reactance of the transparent matcher as a function of displacement  $l$  from an arbitrary reference be  $X(l)$ , then the impedance of the cavity/matcher combination in the transmission line model,  $Z_g$ , is given by:

$$Z_g = Z_b \pm jX(l) \quad (5)$$

where  $Z_b$  is defined in the same way as  $Z_c$  but includes the effect of beam loading:

$$Z_b = R_b \cdot \cos \psi \cdot e^{j\psi} \quad (6)$$

To minimise reflected power back to the rf source,  $Z_g$  must be real and equal to the characteristic impedance of the waveguide equivalent transmission line  $Z_0$ .  $X(l)$  can be set at will by adjustment of the dynamic matcher position. Thus a range of values of  $\psi$  can be found that will allow equation

(5) to be solved with  $Z_g$  taking any purely real value greater than or equal to  $Z_0$ . The solution of (5) then yields:

$$X(l) = \pm Z_0 \cdot \sqrt{\left[ \frac{R_b}{Z_0} - 1 \right]} \quad (7)$$

Inspection of (7) reveals that the matching technique will only work for  $R_b > Z_0$ . In Helios 1  $R_0$  is 2.6 times  $Z_0$  thus the matching system has the potential to produce up to 1.6 times  $P_{\text{cu}}$  as synchrotron light. Substitution of the relation for the reactance of a short circuit length of waveguide or transmission line into (7) gives the required dynamic matcher position  $l$  as a function of cavity beam loading:

$$\beta \cdot l = \pm \arctan \sqrt{\left[ \frac{R_b}{Z_0} - 1 \right]} + \beta \cdot l_0 \quad (8)$$

Here  $\beta$  (radians/per unit length) is the phase constant of the waveguide and  $l_0$  is an arbitrary offset in the transparent matcher position that is most easily determined by measurement. Substitution of (3) in (8) completes the dynamic matcher position calculation that must be solved typically at one second intervals as the beam is ramped to full energy and then gradually decays over time.

In addition to calculating the dynamic matcher position, the Helios 1 control computer must also control an electronic phase shifter in one arm of the phase null detector driving the tuner. It was shown that in order to solve (5) the cavity must introduce a reactive impedance in order to provide a purely resistive load for the source, thus the phase shifter in figure 2 must be adjusted by  $\psi$  radians when the dynamic matcher moves from the position where it produces zero reactance (the short circuit position) to the position calculated by (8).

As a result of operational experience, further offsets are also applied to this phase shifter in order to compensate for some beam-cavity instabilities. This is explained in section 4.1.

## 4. OPERATIONAL EXPERIENCE

### 4.1. Cavity de-tune control

While the above analysis provides the means to present the source with a perfectly matched load (zero reflected power), in practice some de-tuning of the cavity from the setting where it produces no reflected power is necessary to ensure a stable stored beam.

Experience has shown that the upper limit of de-tuning required seems only to be set by the tolerance to reflected power of the rf source and the need to maintain a certain minimum cavity voltage. From the point of view of beam stability, there seems to be no upper limit. Expressed in terms of an offset to  $\psi$ , while typically  $32^\circ$  is necessary to guarantee beam stability at injection energy, this reduces progressively to as little as  $5^\circ$  at full energy.

During commissioning a continuously adjusting method of optimising the cavity de-tune was developed. This involves monitoring the reflected power reaching the rf source and incrementing or decrementing the calculated de-tune to maintain the reflected power within pre-programmed limits. This de-tune modification technique has been used to ramp currents of more than 290 mA to full energy and is now in routine use for Helios.

Further improvement in the amount of current that could be consistently stored at injection was found to be possible by de-tuning the output cavity of the rf source klystron. This is now tuned 7 MHz low in frequency with an approximately 3 dB penalty in terms of available power output from the tube.

#### 4.2. Stored beam performance

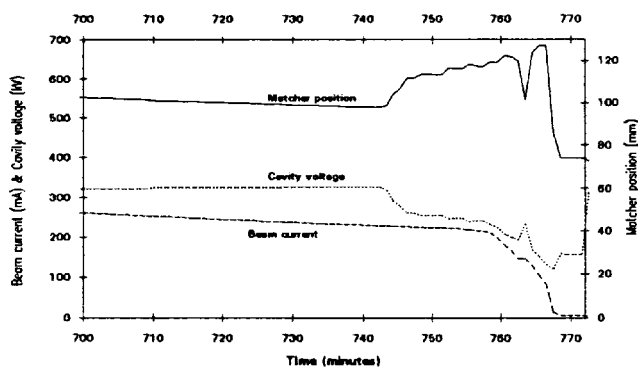

Figure 3. Matcher movement in response to a change in cavity voltage and stored current at full energy

As an illustration of the matcher movement algorithm in operation, figure 3 is a plot of data recorded during an experiment made to investigate the effect of cavity voltage on beam decay. The first part of the plot shows the normal gradual beam decay, then (at 740 mins.) the cavity voltage was steadily reduced by manual control with a trackerball. As the cavity voltage and stored current change, the matcher software moves the matcher to compensate. Initially the matcher software moves the matcher to a higher setting compensating for the increased beam loading caused by the steadily dropping cavity voltage. The only exception to this trend is a short period when the cavity voltage was increased again (with a corresponding reversal in the direction of matcher motion). The cavity voltage was eventually reduced to such an extent that the stored beam began to decay rapidly. Finally the stored current became so small that the correspondingly reduced beam loading allowed the matcher to return towards its non beam loaded position (at 767 mins).

#### 5. CONTROL ELECTRONICS

In normal operation the cavity rf system, along with the rest of the synchrotron subsystems, are remotely controlled via a MicroVAX minicomputer and CAMAC data highway [4]. A single rack of electronics interfaces to CAMAC and,

amongst other functions, controls transmitter drive, cavity voltage, tuner and matcher position.

Figure 4 illustrates in block diagram form the cavity voltage control loop including the reverse power limiting section. This requires two non-linear elements.

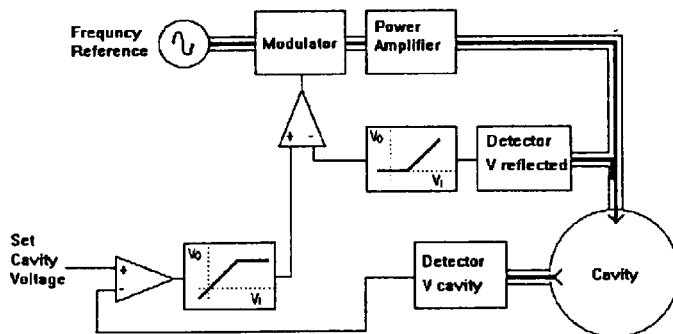

Figure 4. Cavity voltage control loop

The first non-linear element in the reflected power path ensures that the reflected power limiting circuit ignores any reflected power signal of less than approximately 700 W. The second non linear element in the cavity voltage control path clamps the cavity voltage drive signal, so preventing the voltage control loop from compensating for the drive reduction being caused by the reflected power signal.

The ratio of the reflected power control loop gain to cavity voltage control loop gain is also important. This is currently set at approximately 4 which prevents the power reflected back to the rf source increasing above its 2kW threshold even with the cavity totally de-tuned.

#### 6. CONCLUSION

A wealth of operational experience has now been accumulated on the Helios 1 rf system. The position of the dynamic matcher is calculated from measurements of stored beam current, beam energy and cavity voltage, no further correction to its position is required. This combined with a reflected power influenced cavity de-tuning algorithm and appropriately designed control electronics is sufficient to store and ramp well in excess of Helios 1's design current of 200 mA without the use of a circulator.

#### 7. REFERENCES

- [1] D. M. Dykes and B Taylor, "Further development of the SRS RF system", Daresbury Laboratory preprint DL/SCI/P544A, March 1987, Daresbury.
- [2] R. J. Anderson *et al*, "Report on Helios: Routine Operation", Paper WEC02B at this conference
- [3] A Gamp, "Servo control of RF cavities under beam loading" DESY HERA 91-09, May 1991, DESY, Hamburg
- [4] A. R. Jorden *et al*, "Control System for a Compact Synchrotron", Nuclear Instruments and Methods in Physics Research, A293, North-Holland, Elsevier Science Publishers B.V., 1990, pp 70-73.